

bowl blank to be 11"dia. x3.5" thick cut  
 round. blade set to 3" high  
 bearings = R8-2RS qty 4  
 1/2" threaded rod pieces: 4", 4" & 8"

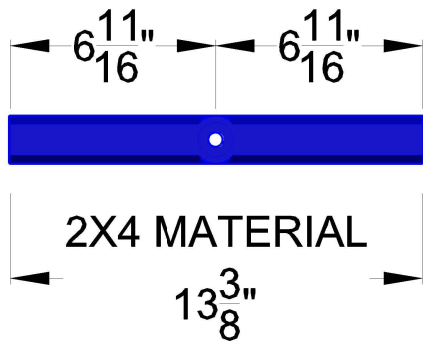

bowl blank to be 11"dia. x3.5" thick cut round. blade set to 3" high  
 bearings = R8-2RS qty 4  
 1/2" threaded rod pieces: 4", 4" & 8"

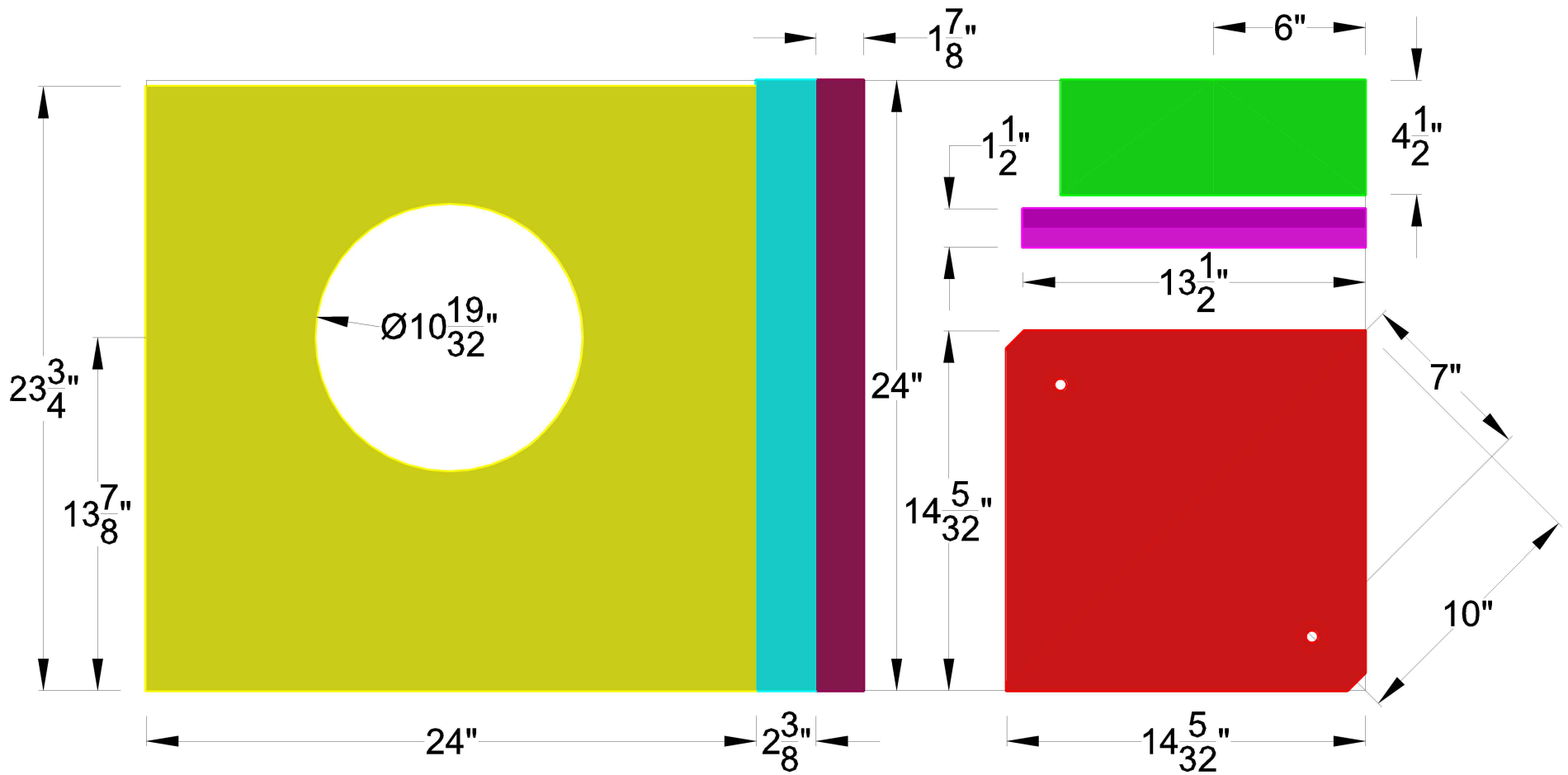